

yuwell



BreathCare (CPAP/APAP) Series of Positive Pressure Breathing Machines

User Manual

Prior to use, be sure to read this manual and follow the use instructions

For the production date, see the certificate or package

Contents

I. Intended uses	1
II. Use notes	1
III. Side effects	1
IV. Product packing list	2
V. Product instructions	2
VI. Button instructions	3
VII. Installation	3
VIII. Start/stop therapy	5
IX. Function instructions	5
1. Information inquiry:	5
2. Delay pressure rise	6
3. Heated humidification level	6
4. Pressure drop level	7
5. Other functions	7
X. Clinical menu	8
XI. Maintenance	10
1. Disassembly	10
2. Cleaning	11
3. Inspection	11
4. Reassembly	12
XII. Therapy parameter storage	13
XIII. Carrying	13
XIV. Troubleshooting	14
XV. Warnings and notes	15
XVI. Technical specifications	17
XVII. Symbols	19
XVIII. Warranty period	20

Dear customers:

This user manual covers the guides for installation, use and routine maintenance and other aspects of YH-360CPAP/YH-380CPAP/YH-560APAP/YH-580APAP (hereinafter referred as BreathCare series of positive pressure breathing machines).

Warning

Please be sure to read the user manual and follow the instructions before use.

Note

The breathing machine is soled only by professional doctors or based on the prescription.

I. Intended uses

BreathCare series of positive pressure breathing machine is used for the therapy of sleep apnea syndrome for adults. The breathing machine is a home breathing machine.

II. Use notes

The product can not be used for airway pressure positive therapy for the user with any of the following diseases; if it must be used, some special attentions should be given. In any case, it can only be determined by a competent physician whether to use the breathing machine. These diseases include:

Heart function problems, severe hypotension, high risk barotrauma, severe lung, pneumothorax, dehydration, cerebrospinal fluid leakage, recent intracranial surgery, intracranial trauma and etc.

III. Side effects

During the therapy with the breathing machine, the following adverse reactions may occur:

Dry mouth, nosebleeds, bloating, ear or sinus discomfort, eye irritation, rash and etc.

Note

If the user has a chest pain, severe headache or breathing difficulty, the physician or agents should be promptly contacted. If the user has an upper respiratory viral tract infection, the therapy should immediately stop.

IV. Product packing list

Name	Quantity	Name	Quantity
Breathing machine	1	Heated Humidifier	1
Air hose	1	Power adapter and power cable	1
User manual	1	Oxygen mask and accessories (nose mask)	1
Carrying kit	1	Micro SD card (YH + 360/YH – 380, no this card)	1
Air filter cotton	2		

V. Product instructions

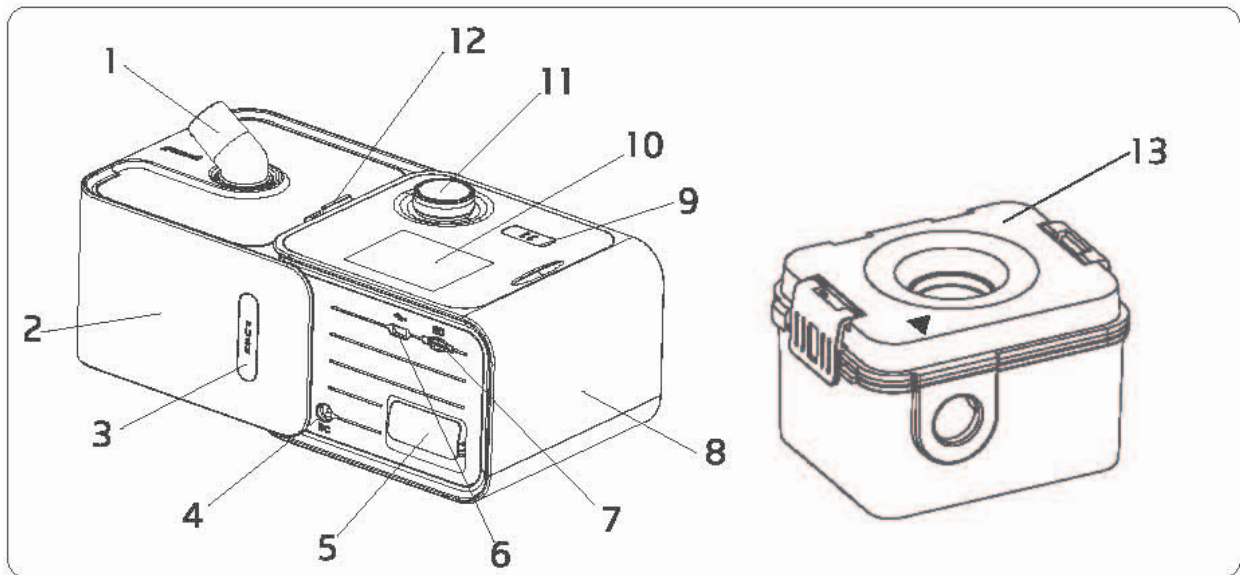

- | | | | | |
|-------------------------|-----------------------|----------------------|--------------------|---------------|
| 1. Air outlet | 2. Heated Humidifier | 3. Hook button | 4. Power connector | 5. Air filter |
| 6. Data connection port | 7. Micro SD card slot | 8. Breathing machine | 9. Start button | 10. Screen |
| 11. Knob | 12. Dial button | 13. Humidifier tank | | |

VI. Button instructions

Start

In the standby status, press this button to start the therapy; in the therapy status, press this button to stop the therapy.

“Start/Stop” function knob



Knob

Press the knob to enter the selected interface or select the items or save the settings; turn the knob to adjust the selected items; rotate clockwise the knob to increase the selected setting parameters and rotate counter clockwise the knob to decrease the selected setting parameters.

VII. Installation

Note

- When the water is filled into the humidifier tank, do not exceed the maximum level  **MAX**; otherwise the water may be entered into the air hose and the breathing machine.
- The distilled water should be used; if there is no distilled water, the tap water should be heated to 100°C and cooled to the room temperature and is filled into the humidifier tank.

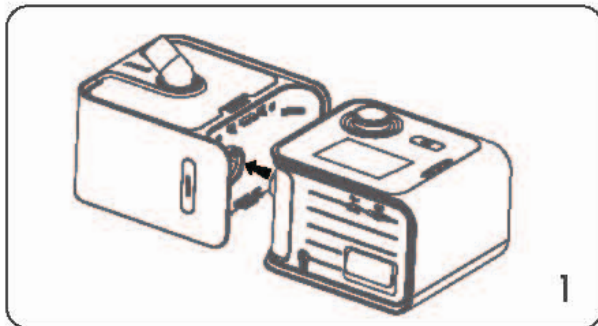

1. Connect the heated humidifier and the breathing machine together.

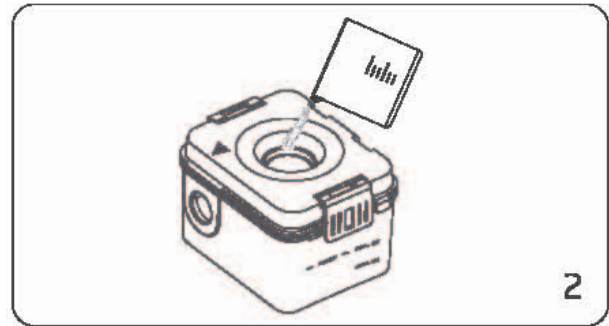

2. Take out the humidifier tank from the heated humidifier, and fill the distilled water into the humidifier tank through the round hole on it to an appropriate level below the maximum level.

 It is proposed to replace the distilled water in the humidifier tank everyday

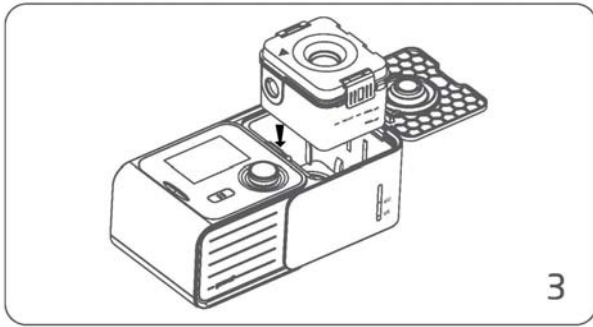

3. Place the humidifier tank back in the heated humidifier in the triangular arrow direction.

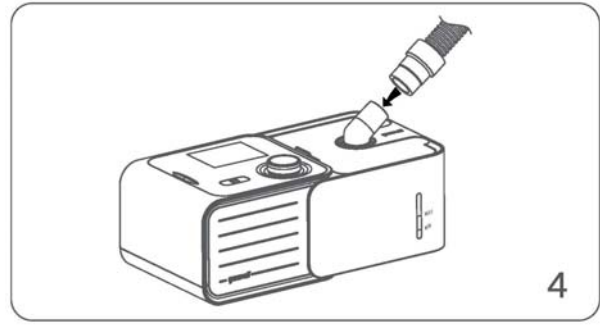

4. Connect properly one end of the air hose to the outlet on the heated humidifier.

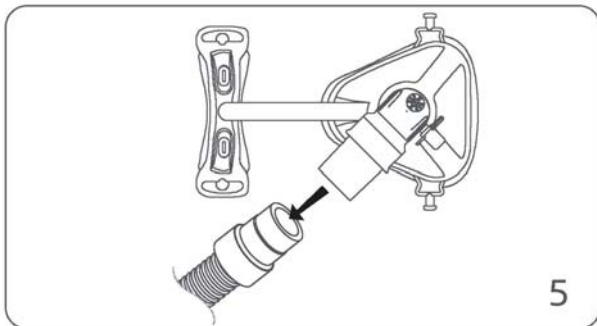

5. Connect the other end of the air hose to the matched nose mask. For more details, please see the nose mask user manual.

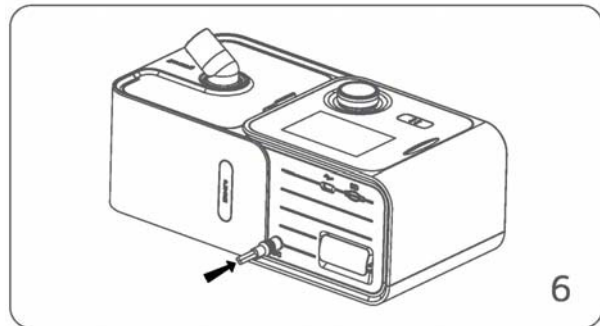

6. Place the breathing machine on a level surface, and connect it with the power supply.

VIII. Start/stop therapy

1. Wear the nose mask according to the requirements in the nose mask user manual;
2. Press “Start” button to start the therapy. During the therapy, the real-time average pressure, the set pressure, the delay pressure rise time (min), and the heated humidification level will be displayed on the screen.
3. Press again “Start” button to stop the therapy.
4. When the screen goes to sleep, press any button to wake it up and then press “Start” again to stop the therapy.

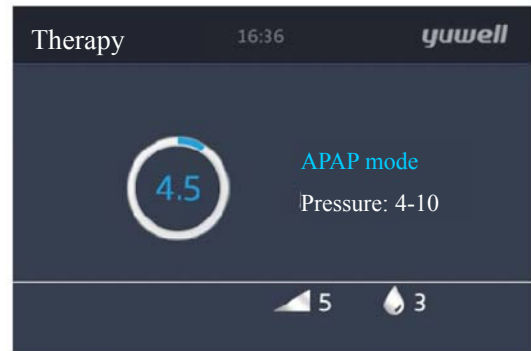

Fig. 1: Therapy start interface

IX. Function instructions

1. Information inquiry:

After the standby interface is transferred to the information interface, a summary of the user sleep report will be shown, including the following contents:

- **AHI:** indicates the number of apneas and hypopneas produced per hour.
- **Single use time:** the time duration for the last therapy (h).
- **Single use average pressure:** the average pressure for the last therapy (cmH20/hPa).
- **Single average air leakage volume:** average air leak volume per minute for the last therapy (LPM).
- **Total therapy time:** the total therapy time after the last therapy time (h).
- **Version information:** software version number used on the breathing machine.
- **Serial Number:** the serial number of the breathing machine.

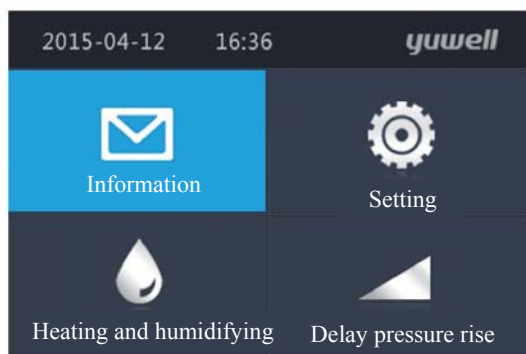

Fig. 2-1: Index information query

AHI	6.2
Single use time	1.7
Single use average pressure	38.1
Single average air leakage volume	0.0
Total therapy time	0.0
Version information	V1.00.00HNF

Fig. 2-2: Therapy query

2. Delay pressure rise

It will make the therapy start more comfortable to enable this function; the delay pressure rise time is the time duration increased from the initial pressure gradually to the minimum pressure or the therapy pressure. The delay pressure rise range is 0-45min, with a level for each 5min.

How to adjust the delay pressure rise level:

- Locate the cursor on the delay pressure rise button, press the knob to enter into the delay pressure rise setting interface.
- Turn the knob to select the delay pressure rise time.
- Press the knob again to save the settings and return to the standby interface.

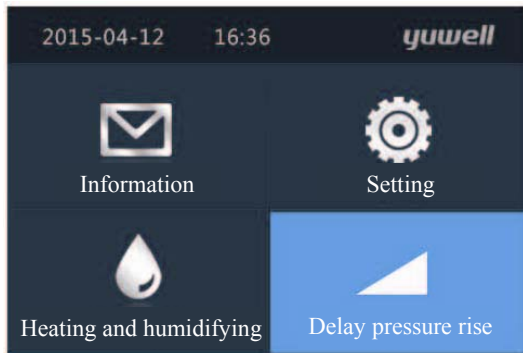

Fig. 3-1: Delay pressure rise setting



Fig. 3-2: Delay pressure rise setting

3. Heated humidification level

The heated humidifier is used for air heated humidification, making the therapy more comfortable. During the therapy, if the user feels thirsty, the heated humidification function can be turned on; if there is some water vapor in the user mask, the heated humidification level should be reduced. There are 0-6 heated humidification levels, Level 0 is to turn off the heated humidification function, Level 1 is the lowest heated humidification level and Level 6 is the highest heated humidification level. The heating coil settings (Levels 1-6) are equivalent to the following temperatures (with the accuracy of $\pm 4^{\circ}\text{C}$) (Note: This temperatures are measured without the humidifier tank):

Level 1 = about 33°C , Level 2 = about 35°C , Level 3 = about 40°C , Level 4 = about 45°C , Level 5 = about 50°C , Level 6 = about 55°C

How to adjust the heated humidification level:

- Locate the cursor in the heated humidification option, press the knob to enter into the heated humidification level setting interface.
- Turn the knob to select the heated humidification level, and then press the knob to save the settings and return to the standby interface.
- During the therapy, press and turn the knob to adjust the heated humidification level, and press again the knob to save the settings.

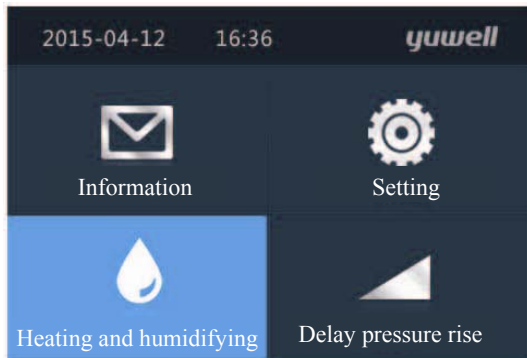

Fig. 4-1 Pressure drop level



Fig. 4-2: Heated humidification level setting

4. Pressure drop level

There are 0-3 pressure drop levels, Level 0 is to disable this function, Level 1 is the lowest level and Level 3 is the highest level, with the maximum expiratory pressure drop. This function can help users to quickly adapt to the therapy from the breathing machine.

5. Other functions

- **Humidifier indicator:** Turn on the humidifier indicator switch to turn on this indicator, for a clear lighting for the remaining level in the humidifier tank.
- **Audible alarm:** if this switch is turned on, an alarm will be sent when the breathing machine has a leak alarm or a motor failure.
- **Automatic start/stop:** If this function is enabled, when you wear a nose mask, the breathing machine will be started automatically; when you remove the nose mask, the breathing machine will stop automatically after 1min.
- **Pressure drop level:** there are 0-3 pressure drop levels; the higher the level is, the breathing is easier.
- **Time settings:** it is used to adjust the time (year, month, day, hour, minute) displayed on the breathing machine.
- **Language:** English or Chinese user interface can be selected.
- **Clock:** the clock function can be enabled and the alarm time (hour, minute) can be adjusted.

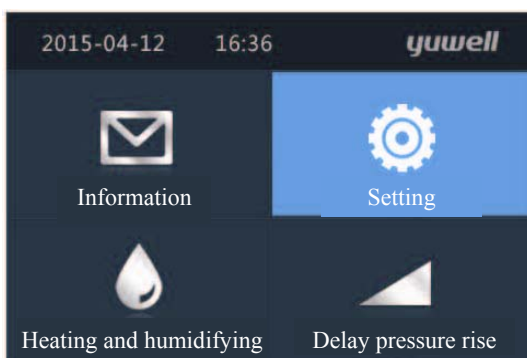

Fig.5-1: Interface setting

Setting	Value
Humidifier indicator	Off
Audible alarm	Off
Automatic start/stop	On
Pressure drop level	Off
Year	2015
Month	04

Fig.5-2: Interface setting

X. Clinical menu

It is proposed to set the following parameters based on the physician suggestions.

1. Select the operation mode

- In the standby interface, hold down “Start” and “Button” to enter into the clinical menu (Fig. 6-1);
- Turn the knob to locate the cursor on the mode option, press the knob to change the font from white to blue, and rotate the knob to select CPAP or APAP mode (no APAP mode on YH-360CPAP / YH-380CPAP);
- After the desired mode is selected, press the knob to save the settings;
- Turn the knob to locate the cursor on the return option and press the knob to return to the standby interface (Fig. 6-2).

2. Set the pressure

- In the clinical menu, select CPAP mode, locate the cursor on the initial pressure (P_{init}) or the therapy pressure (P_{th}) option, press the knob to change the font from white to blue, and rotate the knob to select the desired pressure;
- Rotate the knob to the left or right to adjust the desired pressure, with each section of the pressure rise/drop level of 0.5cmH₂O/hPa;
- After the desired therapy pressure is selected, press “Knob” button to save the settings;
- Turn the knob to locate the cursor on the return option, and press the knob to return to the standby interface (Fig. 6-2)
- In APAP mode, used the same operation commands to set the maximum pressure (P_{max}), minimum pressure (P_{min}), therapy pressure (P_{th}) and initial pressure (P_{init}). (Note: there is no therapy pressure option in online APAP mode)

Description

In APAP mode, when the set maximum pressure is lower than the initial pressure, therapy pressure and minimum pressure, the initial pressure, therapy pressure and minimum pressure will be automatically set as the maximum pressure.

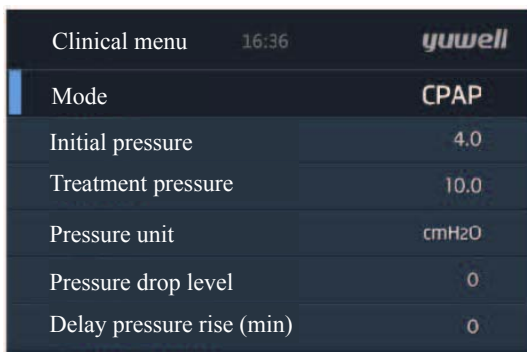

Clinical menu 16:36 yuwell	
Mode	CPAP
Initial pressure	4.0
Treatment pressure	10.0
Pressure unit	cmH ₂ O
Pressure drop level	0
Delay pressure rise (min)	0

Fig. 6-1: CPAP setting in the clinical menu

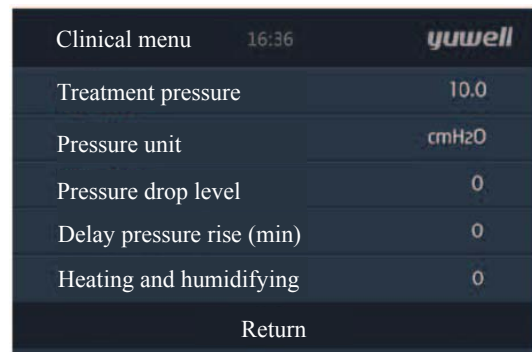

Clinical menu 16:36 yuwell	
Treatment pressure	10.0
Pressure unit	cmH ₂ O
Pressure drop level	0
Delay pressure rise (min)	0
Heating and humidifying	0
Return	

Fig. 6-2: CPAP setting in the clinical menu

3. Select the pressure unit

- In the clinical menu, Rotate the knob to locate the cursor on pressure unit option, press the knob to change the font from white to blue, and rotate the knob to select cmH₂O or Pa;
- Press the knob to save the setting;
- Turn the knob to locate the cursor on the return option and press the knob to return to the standby interface (Fig. 6-2).

4. Select the pressure drop level

- In the clinical menu, rotate the knob to locate the cursor on the pressure drop level option, press the knob to change the font from white to blue, and rotate the knob to select the pressure drop level (among Levels 0-3);
- Press the knob to save the setting;
- Turn the knob to locate the cursor on the return option and press the knob to return to the standby interface (Fig. 6-2).

5. Select the delay pressure rise level (min)

- In the clinical menu, rotate knob to locate the cursor on the delay pressure rise (min) level option, press the knob to change the font from white to blue, and rotate the knob to select the delay pressure rise time (0-45min, 5min/level);
- Press the knob to save the setting;
- Turn the knob to locate the cursor on the return option and press the knob to return to the standby interface (Fig. 6-2).

6. Select the heated humidification level

- In the clinical menu, rotate the knob to locate the cursor on heated humidification level option, press the knob to change the font from white to blue, and rotate the knob to select the heated humidification level (among Levels 0-6);
- Press the knob to save the setting;
- Turn the knob to locate the cursor on the return option and press the knob to return to the standby interface (Fig. 6-2).

Note

During the therapy, simultaneously press and hold “Start” and “Button” to enter into the clinical menu, perform Steps 1-6 above to adjust the therapy parameters, and press “Button” on the return option to return to the therapy interface.

XI. Maintenance

The regular maintenance for the breathing machine can ensure that it provides a better therapy quality to users. Its maintenance includes disassembly, cleaning, inspection, reassembly and other aspects.

1. Disassembly

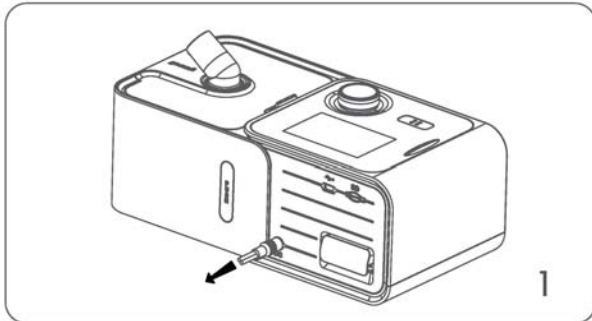

1. Disconnect the power supply for the breathing machine.

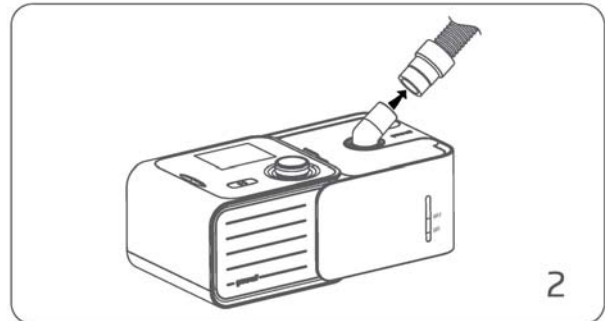

2. Rotate the air hose port and remove the air hose from the breathing machine.

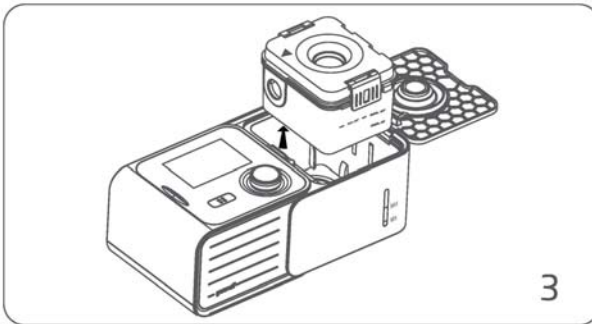

3. Press and hold down the button on the heated humidifier to open the heated humidifier top cover and remove the humidifier tank.



4. Open the humidifier tank top cover and drain the remaining water from the humidifier tank.

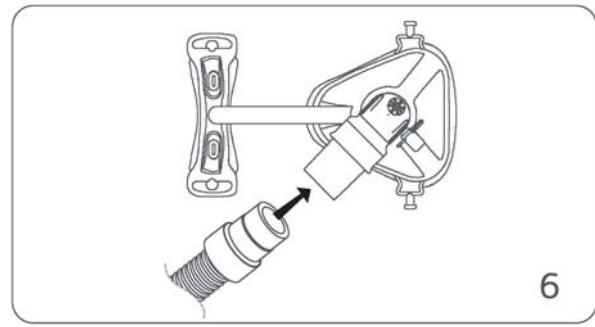
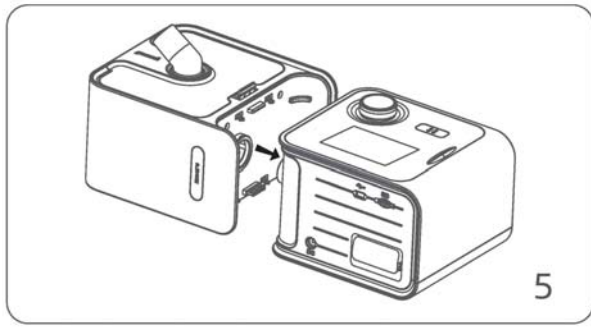

5. Hold the breathing machine and the heated humidifier, press and hold the hook button, to separate the heated humidifier from the breathing machine.

6. Separate the air hose from the nose mask.

2. Cleaning

The breathing machine should be cleaned at least once a week with the following steps. For more details about the nose mask cleaning, please see the nose mask cleaning section in the nose mask user manual.

- Any dust on the breathing machine housing and the heated humidifier housing should be cleaned gently with a clean and damp cloth;
- Fill the warm water (at the temperature of no higher than 41°C) into the humidifier tank and air hose to clean them;
- Clean completely the humidifier tank and the air hose with the warm water, and dry then them in the air;
- Clean the breathing machine housing with a dry and clean cloth.

Note

Do not use a dishwasher or cleaning machine or use the cleaning products with any fragrance or adjusting agent to clean the breathing machine.

3. Inspection

The humidifier tank, air hoses, air filter cottons in the breathing machine should be inspected regularly, to avoid any damage.

A. Humidifier tank inspection:

- If there is any break or crack in the humidifier tank, it should be replaced with a new one;
- If its separator seal is damaged or torn, it should be replaced with a new one.

B. Air hose inspection:

- Inspect the air hose; if there is any tear or damage, replace it with a new one.

C. Air filter cotton inspection:

- Inspect the air filter cotton once a week, and it is recommended to replace the air filter cotton once every 4 weeks;
- If the air filter cotton is damaged or clogged with particulate dusts, replace it with a new one immediately.

D. Air filter cotton replacement steps:

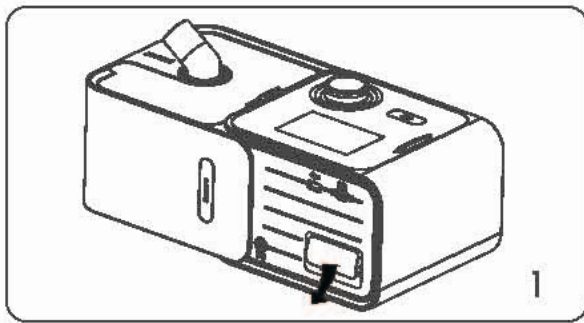

1. Open the cover of air filter cotton, and remove the old air filter cotton.

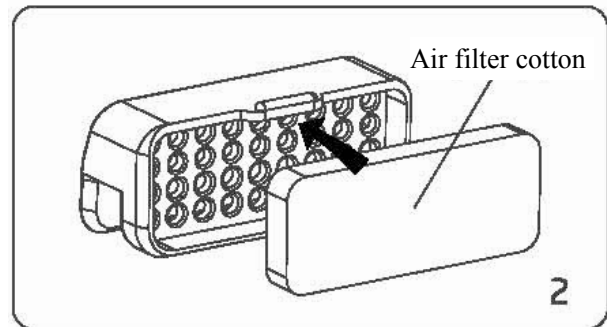

2. Place the new air filter cotton on the filter cover, and install them on a breathing machine.

Note

Ensure that the air filter cotton size is fit, to prevent water and dust from entering into the breathing machine.

4. Reassembly

After the humidifier tank and the air hose are cleaned and dried, re-assemble them together.

- The humidifier tank should be reassembled as shown in the figure. The removable cover, partition, humidifier tank body should be properly installed with their concave positions.

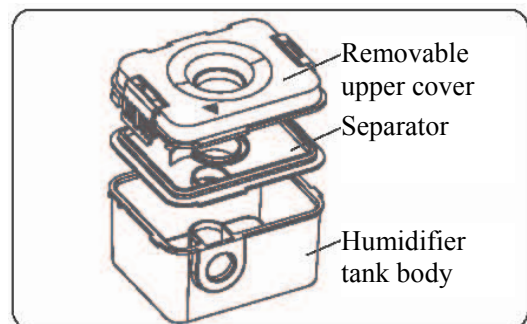

- Hold the heated humidifier, and align its port with the breathing machine port to connect them together;
- Place the humidifier tank into the heated humidifier and close the heated humidifier top cover;
- Connect one end of the air hose to the outlet and connect the other end to the nose mask.

XII. Therapy parameter storage

BreathCare series of positive pressure breathing therapy can automatically store user therapy data for competent physician view, and these therapy data can be used as a basis to adjust the therapy parameters.

1. MicroSD card

When the physician wants to view the user data, the user should turn on the power supply for the breathing machine, insert MicroSD card into the slot to read and write data, and then remove it from the machine after the reading and writing is completed.

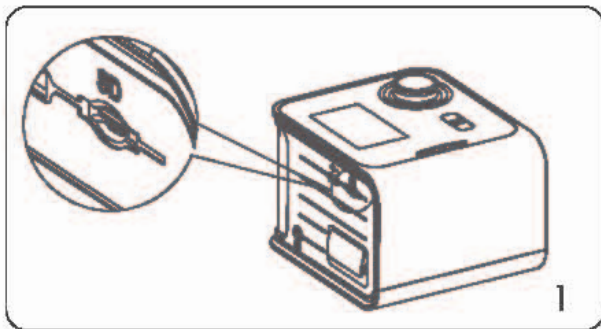

1. Find MicroSD card slot at the back of the breathing machine.

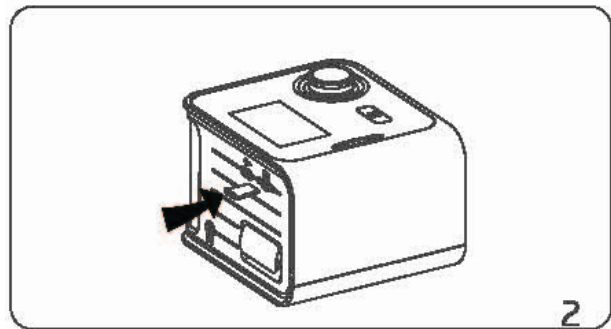

2. Insert MicroSD card into the slot, and press SD card to remove it after the reading and writing is completed.

Note

This MicroSD card can not be used for other purposes.

XIII. Carrying

BreathCare series of positive pressure breathing machine can be carried with you, but the following notes must be paid attention to:

- Must place the breathing machine in the portable product package, to avoid the product damage due to any accident;

- Prior to the product packaging, drain the remaining water in the humidifier tank, separate the heated humidifier from the breathing machine and place them into the packaging according to the instructions of the drawing in the portable kit.

XIV. Troubleshooting

When the breathing machine fails, inspect the items in the table below; if the following methods are still failed to solve the problem, please contact Yuwell customer services. Do not disassemble the machine without permission from Yuwell Company.

- General failures

Failure	Possible causes	Solution
Nose mask leak	<ul style="list-style-type: none"> ● The nose mask is not installed properly ● The nose mask size is unqualified ● The nose mask type is unqualified 	<ul style="list-style-type: none"> ● Install it in accordance with the nose mask user manual ● Replace the nose mask with proper size ● Replace the nose mask type
The nose has dry and obstruction symptoms	<ul style="list-style-type: none"> ● The humidification level is too low ● The nose has other disorders 	<ul style="list-style-type: none"> ● Increase the humidification level ● Consult the physician
There is some water in nose, nose mask or air hose	<ul style="list-style-type: none"> ● The humidification level is too high ● The temperature difference between inside and outside of the hose is big 	<ul style="list-style-type: none"> ● Decrease the humidification level ● Mount a heat shield outside of the hose or replace the hose with heating wire
The mouth feels dry and uncomfortable	<ul style="list-style-type: none"> ● The air is exhaled from the mouth 	<ul style="list-style-type: none"> ● Use the full face mask or contact your physician
The pressure inside the nose mask is too high (the user receives excess air)	<ul style="list-style-type: none"> ● The delay pressure rise function is not enabled 	<ul style="list-style-type: none"> ● Enable the delay pressure rise function

The pressure in the nose mask is too low (the user inhales less air)	<ul style="list-style-type: none"> ● The delay pressure rise function may be enabled 	<ul style="list-style-type: none"> ● When the pressure rises to the minimum pressure or the therapy pressure, start the therapy ● Close the delay pressure rise function
Screen is blank	<ul style="list-style-type: none"> ● The screen backlight will automatically turn off after 2min, to enter into the sleepy status ● The power supply is not connected 	<ul style="list-style-type: none"> ● Press any key to light up the screen again ● Connect the power supply and make sure the good contacts
Humidifier tank leak	<ul style="list-style-type: none"> ● The humidifier tank is assembled incorrectly ● The humidifier tank is damaged 	<ul style="list-style-type: none"> ● Inspect whether the humidifier tank is assembled correctly; if not, reassemble it according to the user manual; ● Confirm whether the humidifier tank for damage; if any, replace it with a new one

XV. Warnings and notes

Warning

- The breathing machine can not be used for a life-support. The breathing machine may stop due to a power outage, but it will not endanger the user;
- The breathing machine can be used together with the supporting mask produced by its original manufacturer or recommended by the physician. Do not clog the air vents on the nose mask, to protect the normal breathing;
- Make sure that the air hose is smooth and not be twisted;
- Make sure that there is any damage on the power cable and the plug;
- Do not place the power cable around any hot objects;
- For any abnormality on the breathing machine, such as abnormal noise, breathing machine or power supply drop from the desktop, breathing machine housing damage and etc, please stop its use and contact immediately Yuwell customer services.

- Do not disassemble the breathing machine by yourself, to prevent electric shock;
- Do not immerse the breathing machine, power adapter, power cable into water; if any water is accidentally spilled on the machine, disconnect the power supply and separate the heated humidifier from the machine to dry the machine in the air, and contact Yuwell after-sales services;
- Before the breathing machine is cleaned, separate the heated humidifier from the breathing machine; after completion of the cleaning, make sure that all parts are completely dried and then reassemble the machine;
- During the breathing machine operation, do not perform any maintenance on it;
- The breathing machine can not be used for the air mixed with flammable anesthetic gases or nitrous oxide gases. (Non-AG or Non-APG breathing machine)

 **Note**

- This product shall be used on a water surface, but should be away from any water source;
- All parts on the breathing machine must be the products from Yuwell Company; the use of any products from any other company may reduce the therapy performance or damage the machine;
- Please use the nose mask with air outlet produced by Yuwell Company. Ensure the mask outlet is clean and smooth, and ensure a fresh air is provided to the nose mask;
- Do not place the breathing machine in location where it is easily crashed or its power cable may be tripped;
- Do not clog the air hose and the air outlet, to avoid overheating of the breathing machine;
- The location to place the breathing machine should be clean and tidy, far away from everything that may clog the outlet or cover the power cable;
- Do not use bleach, chlorine, alcohol, aromatic solution, moisturizer, antibacterial soap, sesame oil and other solutions to clean the breathing machine; otherwise it may result in a danger, affect the humidification effect of the breathing machine, even reduce the service life of the product;
- If a heated humidifier is used, please place the heated humidifier below the user's head level, to prevent that any water backflows into the air hose and the nose mask;
- Before the breathing machine is moved, please drain the remaining water in the humidifier tank. If there is any water in the humidifier tank, do not tilt, flip or shake the breathing machine, to prevent that any water flows into the breathing machine. For more details, see the heated humidifier user manual (P06).













XVI. Technical specifications

Item	Specification	
Power supply	Input voltage: AC100V-240V, Allowable tolerance: $\pm 10\%$, 1.4A; Frequency: 50HZ-60HZ, Allowable tolerance: $\pm 1\%$	
Environmental conditions	Temperature	Operation: $+5^{\circ}\text{C} \sim +35^{\circ}\text{C}$ ($+41^{\circ}\text{F} \sim +95^{\circ}\text{F}$), (non-condensing) Storage: $-20^{\circ}\text{C} \sim +70^{\circ}\text{C}$ ($+4^{\circ}\text{F} \sim +158^{\circ}\text{F}$) Transportation: $-20^{\circ}\text{C} \sim +70^{\circ}\text{C}$ ($+4^{\circ}\text{F} \sim +158^{\circ}\text{F}$)
	Humidity	Operation: Relative humidity 10% ~ 90% (non-condensing) Storage: Relative humidity 10% ~ 90% Transportation: Relative humidity 10% ~ 90% Atmospheric pressure range: 600hPa ~ 1060hPa
EMC	<p>BreathCare series of positive pressure breathing machine can meet EMC requirements of GB9706.1: 2007. This device can provide a reasonable protection against harmful interferences. This device may generate, use, or radiate a radio frequency energy; if it is not installed and used in accordance with the instructions, it may cause a harmful interference to other devices around. However, even if it is installed properly, it can not guarantee that any interference will not occur. If the product has caused a harmful interference to other devices, it is recommended that users try to correct the interference with following ways:</p> <ul style="list-style-type: none"> ● Re-locate or re-set the receiving device. ● Increase the isolation distance to this product. ● Connect the device to the circuit socket that is not supplied for other devices. ● Consult the manufacturer or on-site service technician for help. 	

Security type	Breathing machine: Class II, BF type;	
Noise	Noise level	According to the requirements of ISO-17510-1: 2007 (CPAP mode), under the pressure of 10cmH ₂ O, at the distance of 1mm, when the breathing machine (equipped with heated humidifier) is under normal operation, the noise should be ≤32dB (A), and when the breathing machine (not equipped with heated humidifier) is under normal operation, the noise should be ≤32dB (A).
Physical properties (breathing machine, humidifier and tank)	Size	270mm *135mm *100mm or 10.63” *5.31” *3.94” (L * W * H)
	Weight	About 1560g or 3.44lb (including a heated humidifier)
	Air hose	Plastic hose, 1.8m (approx.)
	Humidifier tank material	PC, injection molding, stainless steel chassis, TPE, seal strip
Treatment pressure	4-20cmH ₂ O/hPa (can be adjusted for rise or drop of 0.5cmH ₂ O/hPa along the section)	
Initial pressure	4-20cmH ₂ O/hPa (can be adjusted for rise or drop of 0.5cmH ₂ O/hPa along the section)	
Maximum pressure	4-20cmH ₂ O/hPa (can be adjusted for rise or drop of 0.5cmH ₂ O/hPa along the section)	
Minimum pressure	4-20cmH ₂ O/hPa (can be adjusted for rise or drop of 0.5cmH ₂ O/hPa along the section)	
Delay pressure rise (min)	0-45min (adjustable, rise/drop 5min per section)	
Maximum air leak compensation	0-130LPM, Allowable tolerance ±5LPM	

XVII. Symbols

The following symbols may be used on the product packaging.

 Please read the user manual prior to use	 Warning or Caution
 BF type	 Class II products
 MAX Maximum water level	 MIN Minimum water level
 Start Start/Stop therapy	 Air flow direction
 SN Product serial number	 IP21 Protection class
 Electrical and electronic waste disposal (WEEE)	 Burning prevision

This product should be recycled by the appropriate electrical and electronic device recycling concentrate station. For more details about this product recycling, please contact the household waste disposal unit local form your local government or the your product retailer.

XVIII. Warranty period

Generally, Suzhou Yuwell Medical Technology Co., Ltd. can provide the warranty periods for the product and its accessories as follows:

Product	Warranty period
Oxygen mask (nose mask)	90 days
Air hose	90 days
Humidifier tank	90 days
MicroSD card	1 year
BreathCare series of positive pressure breathing machine (including a heated humidifier)	2 years
Power adapter	1 year

The warranty period for this product applies only for the original customer, and the product is not transferable.

The product warranty excludes the following cases:

- Any problem due to miss use, disassembly, or modification;
- Any problem due to machine maintenance performed by any company without Yuwell permission;
- Any damage or contamination caused by cigarette, cigarette pipe, cigar or other tobacco goods;
- Any damage caused by that any water is splashed on the electronic device surface or into its interior.

Yuwell Company has the final right to explain the warranty period for this product.

XVIII. Data management software and more details

Download the instructions about “Breathing Machine Management Software” from Yuwell official website www.yuyue.com.cn or dial Yuwell customer service call: 400-8287768

Note

During the therapy process, the breathing machine can not be connected to a PC for data download; otherwise, it may cause a malfunction or damage of the respiratory system.

Cut along the dotted line



BreathCare Series of Positive Pressure Breathing Machine Warranty Card

Manufacturer copy

Manufacturer contact _____	Department _____	User _____
Address _____		
Diagnosis _____	Phone _____	

Product Model _____	Product No _____
Invoice Number _____	Purchase Date _____
Dealer _____	

The following cases are not included in the warranty scope:

1. Failure or damage caused by any unauthorized modification and repair from non-authorized technicians from Yuwell Company.
2. Malfunction or damage caused by any improper use or maintenance.
3. Failure or damage caused by any accident, natural or man-made disaster.
4. Original parts wearing parts and consumables excluded from the manufacturer warranty scope.

User: _____

Date: _____

Cut along the dotted line



BreathCare Series of Positive Pressure Breathing Machine Warranty Card

User copy

User contact _____	Department _____	User _____
Address _____		
Diagnosis _____	Phone _____	

Product Model _____	Product No. _____
Invoice Number _____	Purchase Date _____
Dealer _____	

The following cases are not included in the warranty scope:

1. Failure or damage caused by any unauthorized modification and repair from non-authorized technicians from Yuwell Company.
2. Malfunction or damage caused by any improper use or maintenance.
3. Failure or damage caused by any accident, natural or man-made disaster.
4. Original parts wearing parts and consumables excluded from the manufacturer warranty scope.

User: _____

Date: _____

Production License No.: Suzhou Food and Medical Machinery
Production No. 20140036

Registration Certificate No.: Suzhou Machinery Registration
Authorization No. 20152540266

Product Standard No.: YZB/Su 0194-2015

National service hotline: 400-8287768

800-828 6633

<http://www.yuwell.com>

Registrant/Manufacturer: Suzhou Yuwell Medical Technology Co., Ltd.

Home/Production Address: Jinfeng Road 9#, Science and Technology
Zone of Hich-New District, Suzhou City

Tel.: 0512-67373001

The manufacturer reserves the right to change the contents

Prior to use, be sure to read this manual and follow the use instructions

1030400-0A



Paper